



**Cambridge International Examinations**  
Cambridge International General Certificate of Secondary Education

CANDIDATE  
NAME

CENTRE  
NUMBER

--	--	--	--	--

CANDIDATE  
NUMBER

--	--	--	--



**PHYSICS**

**0625/42**

Paper 4 Theory (Extended)

**October/November 2016**

**1 hour 15 minutes**

Candidates answer on the Question Paper.

No Additional Materials are required.

**READ THESE INSTRUCTIONS FIRST**

Write your Centre number, candidate number and name on all the work you hand in.

Write in dark blue or black pen.

You may use an HB pencil for any diagrams or graphs.

Do not use staples, paper clips, glue or correction fluid.

**DO NOT WRITE IN ANY BARCODES.**

Answer **all** questions.

Electronic calculators may be used.

You may lose marks if you do not show your working or if you do not use appropriate units.

Take the weight of 1.0 kg to be 10 N (acceleration of free fall =  $10 \text{ m/s}^2$ ).

At the end of the examination, fasten all your work securely together.

The number of marks is given in brackets [ ] at the end of each question or part question.

The syllabus is approved for use in England, Wales and Northern Ireland as a Cambridge International Level 1/Level 2 Certificate.

This document consists of **19** printed pages and **1** blank page.

1 Fig. 1.1 shows a student travelling down a hill in an unpowered vehicle.

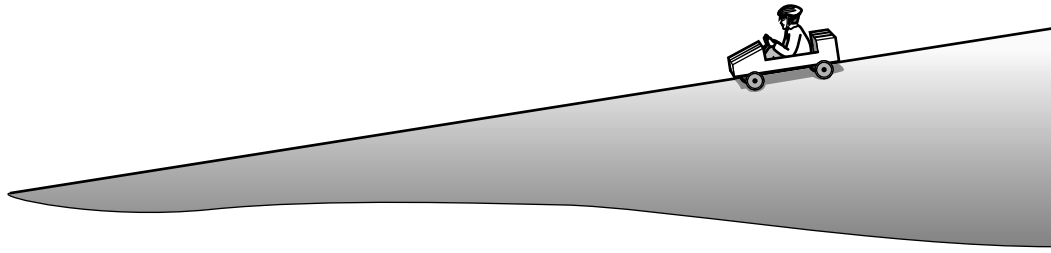

Fig. 1.1

Fig. 1.2 is part of the speed-time graph for the vehicle travelling down the hill.

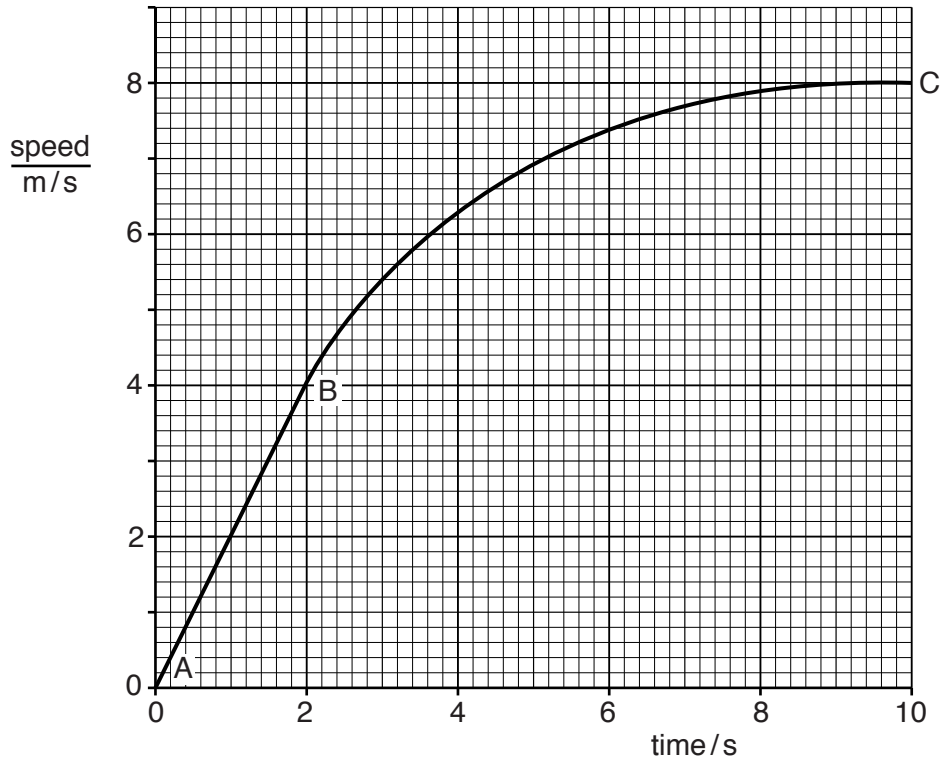

Fig. 1.2

(a) (i) State how the graph shows that the acceleration is constant between A and B.

..... [1]

(ii) Calculate the acceleration between A and B.

acceleration = ..... [2]

(iii) Describe how the acceleration changes between B and C.

..... [1]

(b) Use Fig. 1.2 to obtain an approximate value for the distance travelled by the vehicle in the first 10s, as shown on the graph.

distance = ..... [4]

[Total: 8]

- 2 (a) (i) State an expression for the kinetic energy of an object of mass  $m$  that is moving with a speed  $v$ .

..... [1]

- (ii) State and explain whether kinetic energy is a scalar quantity or a vector quantity.

..... [1]

- (b) Fig. 2.1 shows two fairground “bumper” cars.

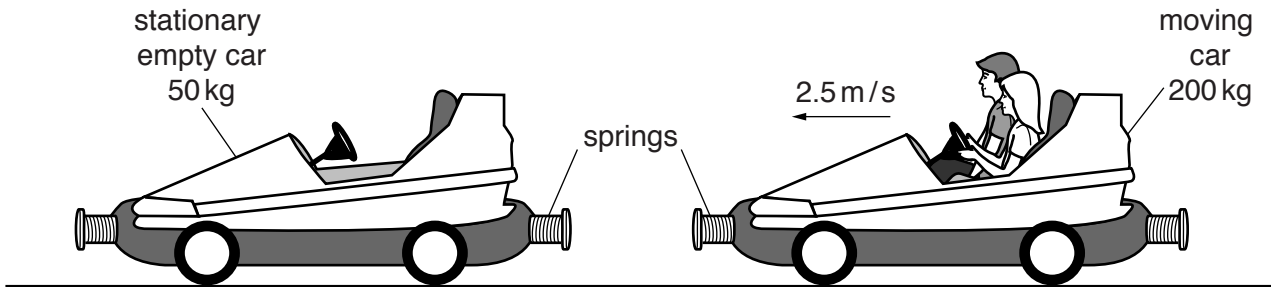

Fig. 2.1

The car with passengers, of total mass 200 kg, is moving in a straight line. It is travelling at 2.5 m/s when it hits a stationary empty car of mass 50 kg.

After the collision, the empty car moves forwards in the same direction at a speed of 4.0 m/s.

For the car with passengers, determine

- (i) its momentum when it is travelling at 2.5 m/s,

momentum = ..... [2]

- (ii) the speed and direction of its motion immediately after the collision.

speed = .....

direction: .....

[3]

(iii) Fixed to the front and the back of the cars are large springs.

When the cars collide the springs compress.

The total kinetic energy of the cars after the collision is equal to the total kinetic energy before the collision.

Describe the energy transfers that occur as the cars collide and then separate.

.....  
.....  
..... [2]

[Total: 9]

- 3 Fig. 3.1 shows a mercury barometer correctly set up to measure the atmospheric pressure in mmHg (millimetres of mercury).

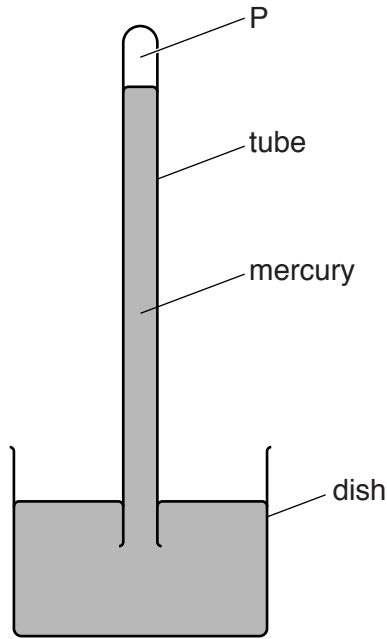

**Fig. 3.1**

- (a) (i) State what is in the space labelled P.  
 ..... [1]
- (ii) On Fig. 3.1, mark carefully the length which gives the atmospheric pressure. [1]
- (iii) The tube containing mercury is pushed further down into the dish.

State what happens, if anything, to the vertical distance between the mercury surface in the tube and the mercury surface in the dish.  
 ..... [1]

- (b) Another barometer is set up incorrectly. The space P contains some air which exerts a pressure equivalent to 15 mmHg. The true atmospheric pressure is 760 mmHg.
- (i) Calculate the reading of atmospheric pressure given by the barometer.

reading = ..... mmHg [1]

- (ii) The tube is now pushed down into the dish so that the volume of the space P is reduced from  $12.0\text{cm}^3$  to  $4.0\text{cm}^3$ .

Calculate the new reading of atmospheric pressure given by the barometer.

reading = ..... mmHg [4]

[Total: 8]

4 A small wind turbine drives a generator to provide electricity for an isolated village.

- (a) The decrease in kinetic energy of the wind striking the turbine is 16200J every second. The output of the generator is 23A at 240V.

Calculate the efficiency of the turbine and generator.

efficiency = ..... [4]

- (b) When electrical energy is not required, the generator charges batteries that then provide electricity during periods of no wind.

State the term used to describe the energy stored in the batteries.

..... [1]

- (c) The use of wind turbines on a large scale has environmental and economic impacts.

Describe one environmental impact and one economic impact.

environmental .....

.....

.....

economic .....

.....

.....

[2]

[Total: 7]



5 (a) State a comparison of

(i) the arrangement of the molecules in ice and in liquid water,

ice .....

liquid water .....

[1]

(ii) the movement of the molecules of ice and liquid water.

ice .....

liquid water .....

[1]

(b) The mass of the ice on an ice-hockey rink is 51 000 kg.

(i) The density of ice is  $920 \text{ kg/m}^3$ .

Calculate the volume of ice on the rink.

volume = ..... [2]

(ii) To form the ice, water at  $0^\circ\text{C}$  was poured onto the floor of the rink and then frozen. The specific latent heat of fusion of ice is  $3.3 \times 10^5 \text{ J/kg}$ .

Calculate the quantity of energy removed from the water to form this ice at  $0^\circ\text{C}$ .

energy = ..... [2]

(c) The temperature of the ice is monitored by a thermometer made up of wires of two different metals connected to a remote voltmeter. The junction of the two wires is embedded in the ice.

State the name of this type of thermometer.

..... [1]

[Total: 7]

- 6 (a) (i) The pitch of a sound wave increases.

Tick **one** box to indicate the change that occurs.

- amplitude decreases  
 amplitude increases  
 frequency decreases  
 frequency increases

[1]

- (ii) The loudness of a sound wave increases.

Tick **one** box to indicate the change that occurs.

- amplitude decreases  
 amplitude increases  
 frequency decreases  
 frequency increases

[1]

- (b) Fig. 6.1 shows an astronaut and a spacecraft on the surface of the Moon, where there is no atmosphere.

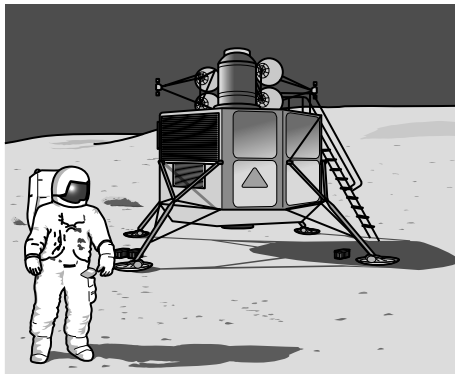

**Fig. 6.1**

A piece of machinery within the spacecraft produces a loud sound of frequency 12 kHz.

Tick the **one** box that indicates the reason why the astronaut cannot hear this sound.

- The material of the space suit is soundproof.  
 Sound cannot travel through a vacuum.  
 Sound of frequency 12 kHz cannot travel through the air in the spacesuit.  
 Sound of frequency 12 kHz cannot be heard by any human ear.

[1]

(c) Some training for space travel is carried out under water.

(i) State an approximate value for the speed of sound in water.

..... [1]

(ii) Calculate the wavelength in water of a sound wave of frequency 12 kHz.

wavelength = ..... [2]

(d) Fig. 6.2 shows successive crests of a water wave approaching a narrow gap in a barrier.

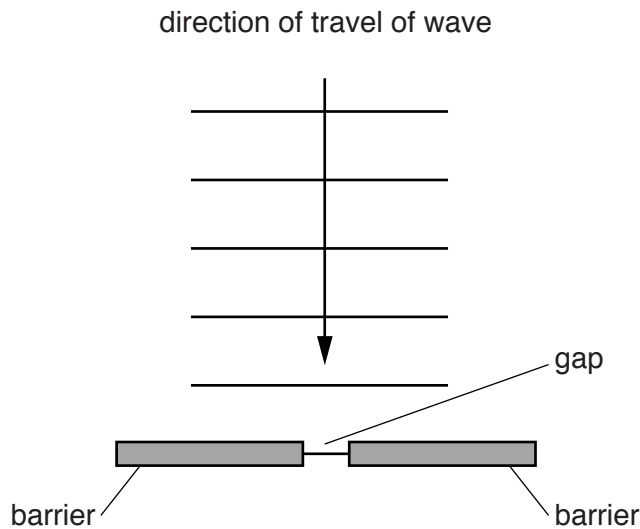

**Fig. 6.2**

On Fig. 6.2, draw three crests of the wave that have just passed through the gap in the barrier.

[3]

[Total: 9]



7 (a) In the space below, draw the circuit symbol for a thermistor.

[1]

(b) Fig. 7.1 shows the connections between two logic gates.

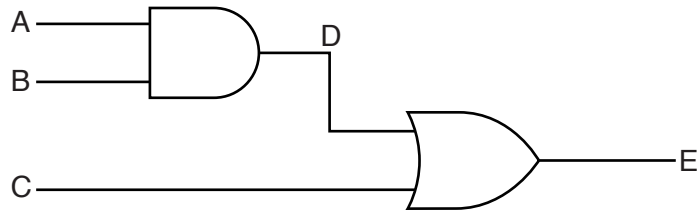

Fig. 7.1

Complete the truth table of this combination of logic gates.

inputs			intermediate point	output
A	B	C	D	E
0	1	1		
1	0	1		
1	1	0		
1	1	1		

[3]

(c) In the space below, draw a truth table to show the action of a NOT gate.

[2]

[Total: 6]

8 A student draws a diagram to represent the electromagnetic spectrum.

Fig. 8.1 is the student's diagram.

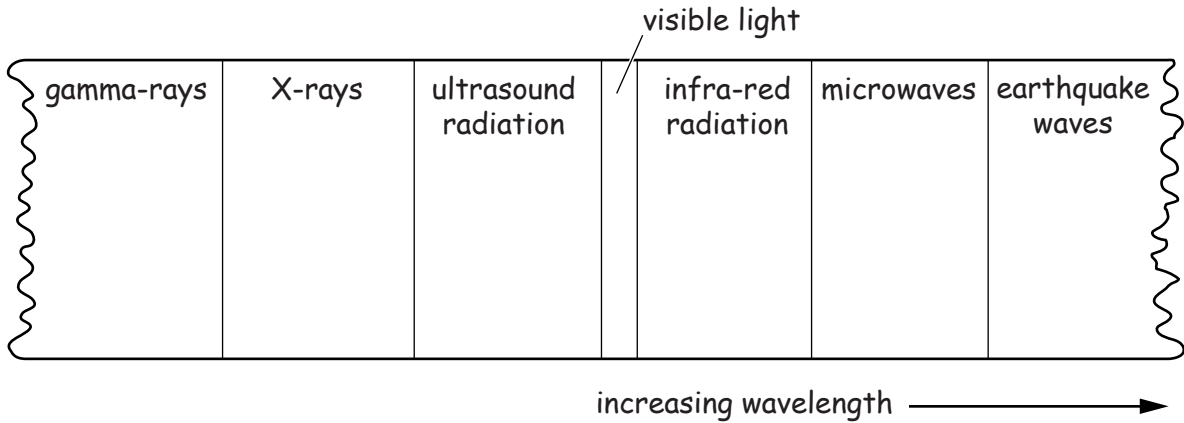

**Fig. 8.1**

The student has made two mistakes.

(a) On Fig. 8.1, cross out what is wrong and correct the diagram. [2]

(b) The speed of light in an optical fibre is  $2.0 \times 10^8$  m/s.

(i) State the speed of light in a vacuum.

speed of light = ..... [1]

(ii) For light in the material from which the optical fibre is made, calculate

1. the refractive index,

refractive index = ..... [2]

2. the critical angle.

critical angle = ..... [2]

(iii) Fig. 8.2 shows a section of the optical fibre.

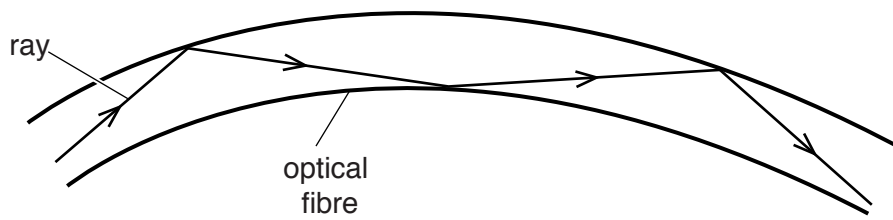

**Fig. 8.2**

Light is travelling in the optical fibre.

State the full name of the process that takes place each time the light changes direction.

..... [1]

[Total: 8]

9 Fig. 9.1 is a circuit diagram.

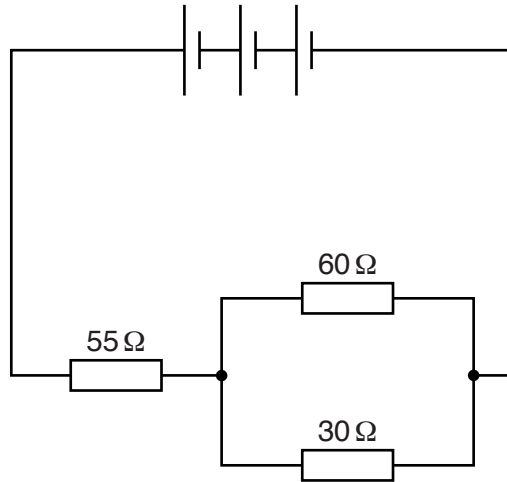

**Fig. 9.1**

The circuit consists of three resistors and three identical 1.5V cells.

**(a)** State the total electromotive force (e.m.f.) of the three 1.5V cells in series.

total e.m.f. = ..... [1]

**(b)** Calculate

**(i)** the combined resistance of the resistors in parallel,

resistance = ..... [2]

**(ii)** the total resistance of the circuit,

resistance = ..... [1]

**(iii)** the current in the 55Ω resistor.

current = ..... [2]



(c) The currents in the  $30\ \Omega$ , the  $55\ \Omega$  and the  $60\ \Omega$  resistors are all different.

State the resistance of the resistor in which the current is

(i) the largest,

resistance = ..... [1]

(ii) the smallest.

resistance = ..... [1]

[Total: 8]

- 10 (a) The size of the charge on an electron is  $e$ . Since the charge on an electron is negative, it is written  $-e$ .

Complete the table by writing down the charges, in terms of  $e$ , on the particles and radioactive emissions shown.

particle	charge
proton	
neutron	
$\alpha$ -particle	
$\beta$ -particle	
$\gamma$ -ray	

[3]

- (b) Fig. 10.1 shows a radioactive source emitting  $\alpha$ -particles,  $\beta$ -particles and  $\gamma$ -rays into a vacuum tube.

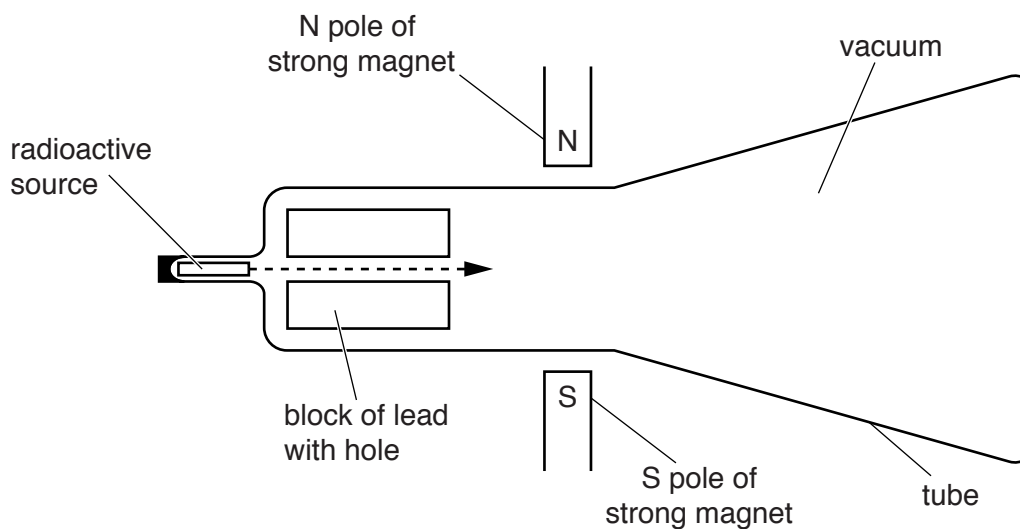

Fig. 10.1

The block of lead ensures that the radiation is in a narrow beam when it passes between the poles of the magnet.

State the direction of any deflection of

- (i) the  $\alpha$ -particles,

.....  
 ..... [1]

(ii) the  $\beta$ -particles,

.....  
..... [1]

(iii) the  $\gamma$ -rays.

.....  
..... [1]

[Total: 6]

11 A radioactive nuclide has a half-life of 4.0 days. A sample contains  $9.6 \times 10^8$  atoms of the nuclide.

(a) Calculate the number of atoms of the nuclide remaining after 12 days.

number = ..... [2]

(b) The count rate from the sample is measured in a laboratory where the background count rate is 16 counts/minute.

A detector is placed at a fixed distance from the sample. The initial count rate measured by the detector is 160 counts/minute.

Calculate the count rate measured by the detector after 12 days.

count rate = ..... [2]

[Total: 4]

---

Permission to reproduce items where third-party owned material protected by copyright is included has been sought and cleared where possible. Every reasonable effort has been made by the publisher (UCLES) to trace copyright holders, but if any items requiring clearance have unwittingly been included, the publisher will be pleased to make amends at the earliest possible opportunity.

To avoid the issue of disclosure of answer-related information to candidates, all copyright acknowledgements are reproduced online in the Cambridge International Examinations Copyright Acknowledgements Booklet. This is produced for each series of examinations and is freely available to download at [www.cie.org.uk](http://www.cie.org.uk) after the live examination series.

Cambridge International Examinations is part of the Cambridge Assessment Group. Cambridge Assessment is the brand name of University of Cambridge Local Examinations Syndicate (UCLES), which is itself a department of the University of Cambridge.